

Installation and Operating Instruction for Irreversible Locks IR

E 08.671e

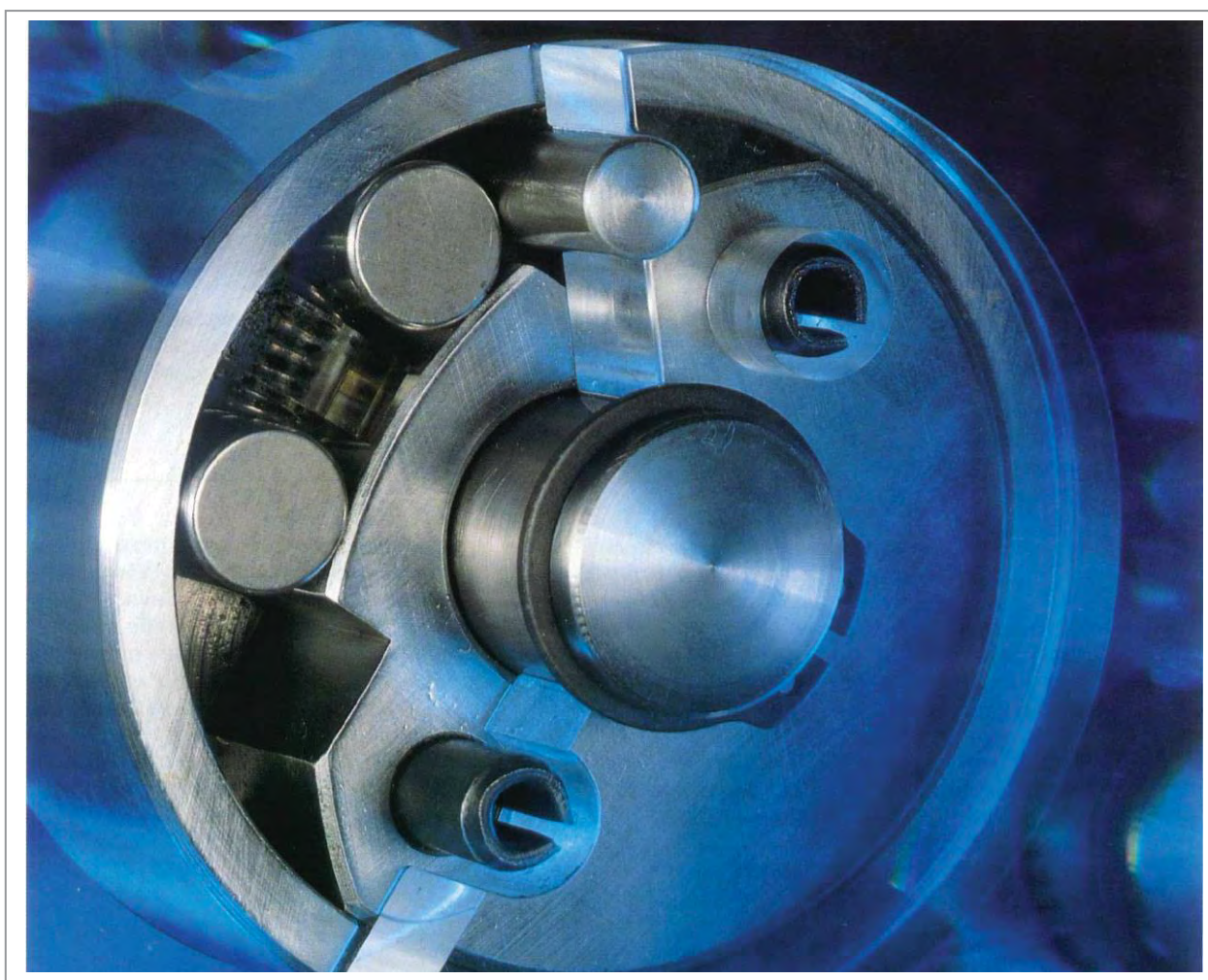

Contact:

Edmayr Antriebstechnik GmbH
Thalham 20, 4880 St. Georgen/Attg.
T: +43 7667 6840 F: +43 7667 20070
office@edmayr.at www.edmayr.at



EDMAYR
ANTRIEBSTECHNIK

EDMAYR ANTRIEBSTECHNIK	Installation and Operating Instruction for Irreversible Locks IR	E 08.671e			
Issue: 29.04.2013	Version : 2	drawn: Su	checked: AB	Pages: 6	Page: 2

Important

Please read these instructions carefully before installing and operating the product. Your particular attention is drawn to the notes on safety.

These installation and operating instructions are valid on condition that the product meets the selection criteria for its proper use. Selection and design of the product is not the subject of these installation and operating instructions.

Disregarding or misinterpreting these installation and operating instructions invalidates any product liability or warranty; the same applies if the product is taken apart or changed.

These installation and operating instructions should be kept in a safe place and should accompany the product if it is passed on to others – either on its own or as part of a machine – to make it accessible to the user.

Safety Notice

- Installation and operation of this product should only be carried out by skilled personnel.
- Repairs may only be carried out by the manufacturer or accredited agents.
- If a malfunction is indicated, the product or the machine into which it is installed, should be stopped immediately and either we or an accredited agent should be informed.
- Switch off the power supply before commencing work on electrical components.
- Rotating machine elements must be protected by the purchaser to prevent accidental contact.
- Supplies abroad are subject to the safety laws prevailing in those countries.

1. General introduction

Irreversible Locks IR are bidirectional acting roller freewheels with bearing support.

The Irreversible Locks IR are used as:

- Bidirectional acting backstops



Caution!

As Freewheels can be used as safety components, it is important to observe these installation and operating instructions carefully.

2. Design

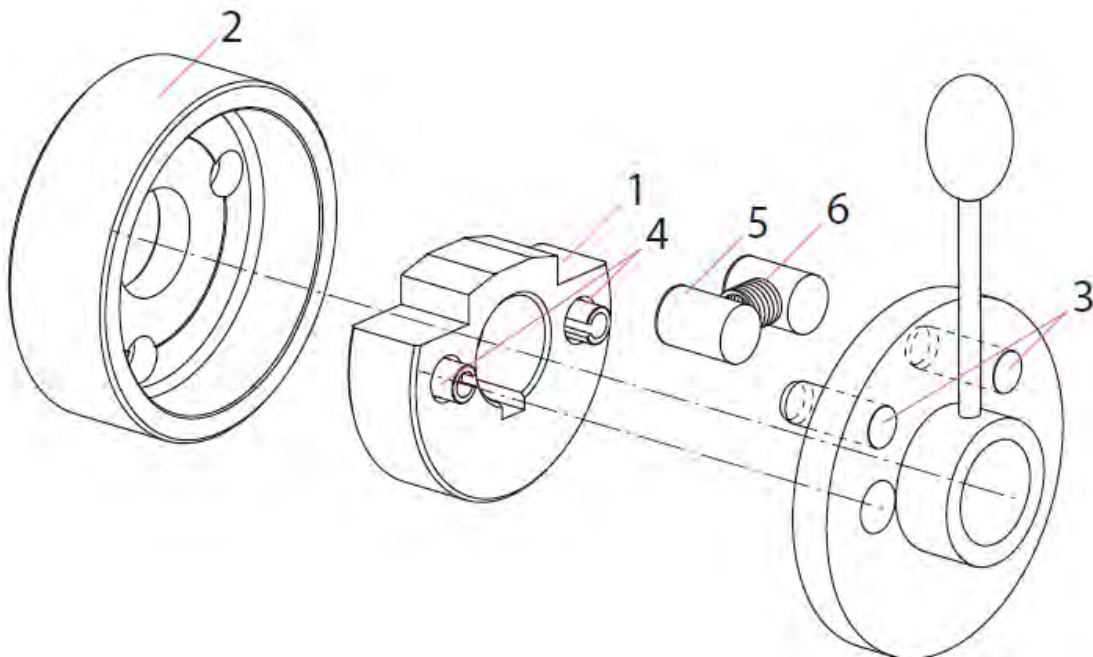

Fig. [1]

The Irreversible Locks are configured shown in Fig. [1].

The essential functional components are the centre body (1), the housing (2), the drive studs (4), the locking rollers (5), the engaging spring (6), and the actuating pegs (3) in the driving part of the customer.

3. Function of the Irreversible Locks

Thus, if force is applied to the driving part, depending upon the direction in which it is applied one or other of the actuating pegs (3) presses one of the two locking rollers (5) out of engagement in opposition to the force exerted by the engaging spring (6). In this way, the driven part connected to the centre body (1) can be rotated without difficulty. When this is done the roller which is still engaged operates as in a freewheel mechanism turning in the freewheeling direction. Due to the symmetrical layout of the irreversible Locks, the process which has just been described can also take place in the same way in the opposite direction of rotation.

If, however, forces coming from the machine attempt to rotate the centre body (1) via the shaft, the centre body is locked to the fixed housing (2) by the locking rollers. Each roller performs this function for one direction of rotation. Thus, the irreversible Locks are not suitable for use where the driven side tends. The Irreversible Locks prevent unwanted adjustments.

**Caution!**

The Irreversible Locks are not suitable for use where the driven side tends to run ahead for the driving side during operation (e.g. for the operation of brakes during descending movements in lifts and hoists).

4. Types

Irreversible Locks IR are available in the standard type.

Standard type

This type is designed for universal use.

It is identified by the suffix „R“ at the end of the product designation.

Example: IR 24 R

**Please note!**

Further information especially on design, function and selection, permissible torques or permissible speeds of these Irreversible Locks is provided in Catalog 84 "Freewheels". Please contact us if you need assistance.

5. General instructions



Caution!

The maximum permissible freewheel torque must not be exceeded due to torque peaks in specific applications.

The maximum freewheel torque should be calculated according to Catalog 84. Please contact us if you need assistance.

Irreversible Locks damage resulting by excessive torque peaks impair component function and can result in excessive overheating of the Irreversible Locks!



Caution!

Torsion vibrations (amplitudes and frequencies which result in engagement and release of the Irreversible locks in rapid succession) must be avoided.

Torsion vibrations can result in overheating and the impairment of the function from the Irreversible Locks!

6. Condition at delivery

The Irreversible Locks are delivered ready for installation. They are packed in anti-corrosion paper.

7. Technical requirements for safe operation

The shaft must be provided with a tolerance of ISO g7.

The parallel key must have back play and may have only minimal width oversize, as otherwise the inner ring may be deformed.

8. Installation



Caution!

Prior to installation of the Irreversible Locks, the parallel key may be not be located in the shaft of the driven part!

Disassemble the Irreversible Locks and cleaning of corrosion protective substance.

Screw the housing (2) directly to the machine housing. For the fastening screws a material quality of 8.8 is sufficient. Tightening torques are to be selected in accordance with VDI 2230 on the basis of the existing friction values in a given case.

EDMAYR ANTRIEBSTECHNIK	Installation and Operating Instruction for Irreversible Locks IR			E 08.671e	
Issue: 29.04.2013	Version : 2	drawn: Su	checked: AB	Pages: 6	Page: 6



Caution!

Screws with material grade 12.9 should not be used because of their low breaking elongation.

Insert for sizes IR12 and IR24 the bearing disc, made of brass, in the housing (2).

Place the parallel key in the shaft of driven part.

Slide now the centre body (1) on the shaft of driven part in the housing (2).

Place the clamping rollers (5) in the clamping pockets between the clamping ramp of the center body and the bore of the housing.

Mount the engaging spring (6) between the clamping rollers.

Slide the customer-side driving part on the drive shaft and secure it axially on these shaft

9. Lubrication

The Irreversible Locks are supplied without lubricant. When mounting, each clamping pocket is to be filled with approximately 1 cm³ of aging resistant liquid grease, e. g. ISOFLEX LDS 18 special A by Fa. Klüber.

10. Maintenance

For each general maintenance the old grease must be removed completely and fill the clamping pockets with new grease.

