

Complete Freewheels FBL

with shaft coupling for large shaft misalignments
with sprags, available in three types

EDMAYR
ANTRIEBSTECHNIK

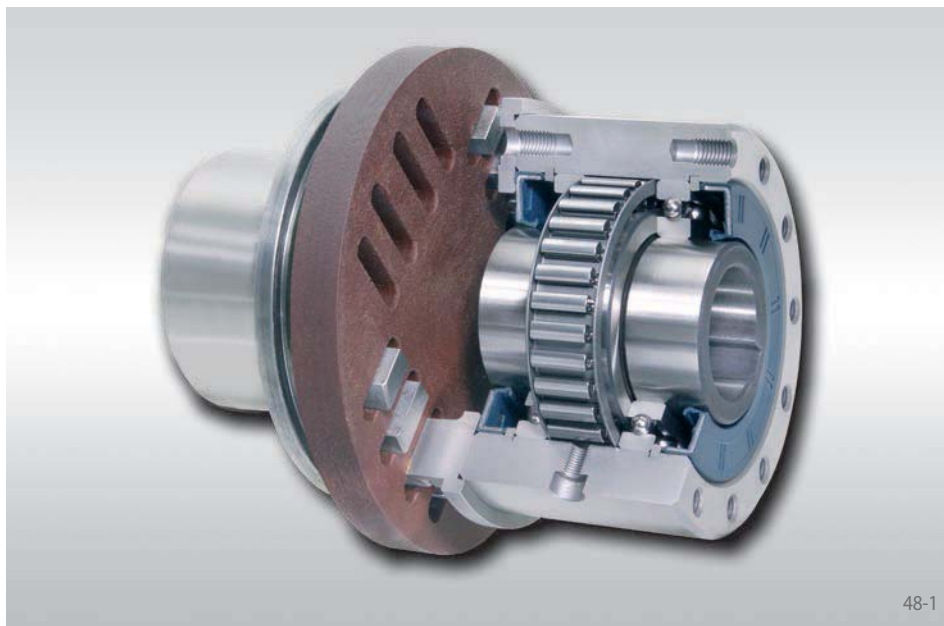

Application as

▶ Overrunning Clutch

Features

Complete Freewheels FBL with RINGSPANN Shaft Coupling are sealed sprag freewheels with ball bearings for coupling two shafts. They are supplied oil-filled and ready for installation.

In addition to the standard type, two other types are available for extended service life.

Nominal torques up to 8 000 Nm.

Bores up to 140 mm. Many standard bores are available.

The torsionally stiff RINGSPANN Shaft Coupling can accept large radial and angular misalignments, without reactive forces affecting neighbouring bearings. We can provide you with performance data upon request.

Application example

Complete Freewheel FBL 82 SFZ as an overrunning clutch in the drive unit of a conveyor belt system with additional creep drive. The freewheel with shaft coupling is arranged in between the main motor and the creep drive. When the creep drive operates, the freewheel is in driving operation and drives the belt at low speed. In normal operation (freewheeling operation), the main motor drives and the outer ring overruns, whereupon the creep drive is automatically disengaged. With the high speed here, the type sprag lift-off Z is used; the sprags work in freewheeling operation without contact and hence are wear-free.

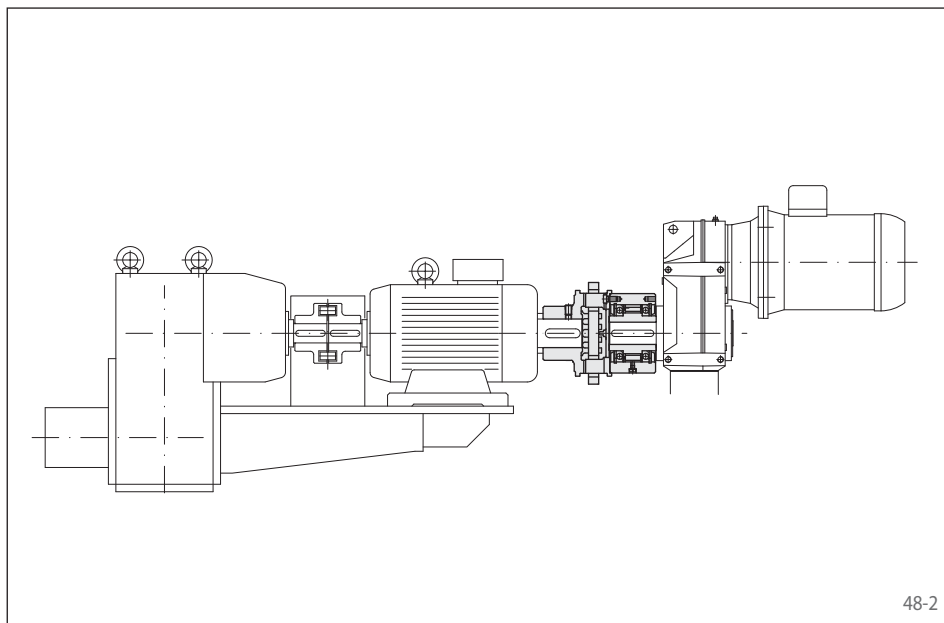

EDMAYR ANTRIEBSTECHNIK GmbH

Thalham 20
A-4880 St. Georgen im Attergau

Tel.: +43 7667 6840
Fax: +43 7667 20070

www.edmayr.at
office@edmayr.at



Complete Freewheels FBL

with shaft coupling for large shaft misalignments
with sprags, available in three types

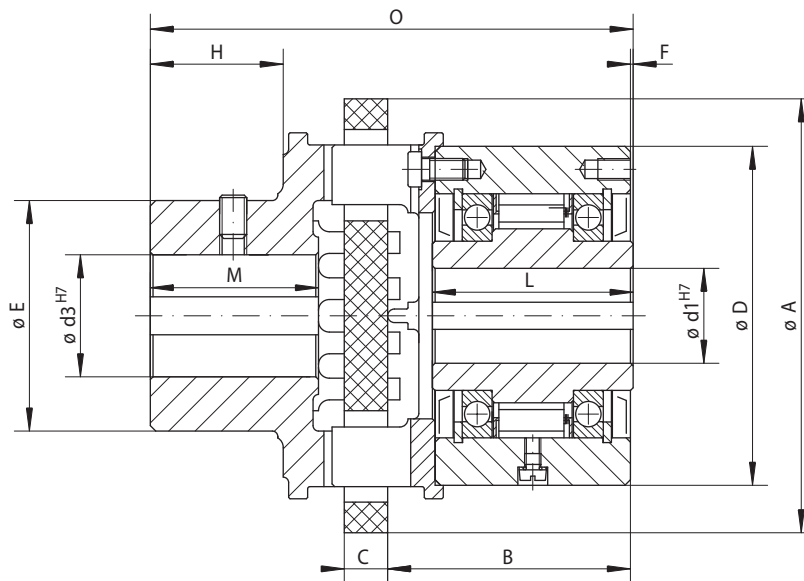

49-1

Overrunning Clutch	Standard type For universal use	Type with RIDUVIT® For extended service life with coated sprags	Type with Sprag lift-off Z For extended service life using sprag lift-off at high speed rotating outer ring

Freewheel Size	Type	Nominal Torque M_N Nm	Max. speed		Type	Nominal Torque M_N Nm	Max. speed		Type	Nominal Torque M_N Nm	Sprag lift-off at outer ring speed min^{-1}	Max. speed	
			Inner ring overruns min^{-1}	Outer ring overruns min^{-1}			Inner ring overruns min^{-1}	Outer ring overruns min^{-1}				Outer ring overruns min^{-1}	Inner ring drives min^{-1}
FBL 37	SF	85	2500	2600	SFT	85	2500	2600	CZ	85	850	3000	340
FBL 44	SF	190	1900	2200	SFT	190	1900	2200	CZ	180	800	2600	320
FBL 57	SF	500	1400	1750	SFT	500	1400	1750	LZ	430	1400	2100	560
FBL 72	SF	500	1120	1600	SFT	500	1120	1600	LZ	500	1220	1800	488
FBL 82	SF	1000	1025	1450	SFT	1000	1025	1450	SFZ	1000	1450	1600	580
FBL 107	SF	2000	880	1250	SFT	2000	880	1250	SFZ	2000	1300	1350	520
FBL 127	SF	4000	800	1150	SFT	4000	800	1150	SFZ	4000	1200	1200	480
FBL 140	SF	8000	750	1050	SFT	8000	750	1050	SFZ	8000	950	1050	380

The maximum transmissible torque is 2 times the specified nominal torque. See page 14 for determination of selection torque.

Freewheel Size	Bore d1		Bore d3		A	B	C	D	E	F	H	L	M	O	Weight
	Standard mm	max. mm	min. mm	max. mm											
FBL 37	20	22*	14	35	110	62,0	12	75	53	0,5	33	48	42	124	3,0
FBL 44	25*	25*	20	42	135	65,0	14	90	66	0,5	41	50	53	140	4,6
FBL 57	30	32*	30	50	160	82,5	16	100	85	0,5	51	65	62	170	6,9
FBL 72	40	42*	30	50	160	89,5	16	125	85	1,0	51	74	62	178	10,0
FBL 82	50*	50*	40	70	200	92,0	20	135	104	2,0	65	75	79	204	14,2
FBL 107	60	65*	50	90	250	111,5	25	170	150	2,5	81	90	100	250	28,0
FBL 127	70	75*	60	110	315	138,0	32	200	175	3,0	101	112	124	313	48,8
FBL 140	90	95*	75	140	400	183,5	40	250	216	5,0	130	150	160	410	102,2

For bore d1: Keyway according to DIN 6885, page 1 • Keyway width tolerance JS10. * Keyway according to DIN 6885, page 3 • Keyway width tolerance JS10.
For bore d3: Keyway according to DIN 6885, page 1 • Keyway width tolerance P9

Mounting

The flexible disk of the shaft coupling must be axially free when fitted so that the ball bearings in the freewheel are not distorted due to heat expansion.

The shaft coupling including the fastening screws are supplied loose. Depending on the desired freewheeling direction, the shaft coupling can be fitted on the right or the left of the freewheel.

The tolerance of the shaft must be ISO h6 or j6.

Example for ordering

Freewheel size FBL 72, type with sprag lift-off Z and 40 mm bore in the freewheel and 50 mm bore in the shaft coupling:

- FBL 72 LZ, d1 = 40 mm, d3 = 50 mm

Edmayr Antriebstechnik GmbH

Thalham 20, 4880 St. Georgen im Attergau

Tel.: +43 7667 6840 Fax: +43 7667 20070

office@edmayr.at

www.edmayr.at