

# Brake Calipers EV 028 FEM and EH 028 FEM

spring activated – electromagnetically released



52-1

## Features

Features	Code
Brake Caliper with electromagnet	E
Mounting to the machine parallel or at right angles to the brake disc	V H
Frame size 028	028
Spring activated	F
Electromagnetically released	E
Manual adjustment to accommodate friction block wear	M
Supply voltage 230 to 415 VAC, supply frequency 50 Hz or 60 Hz adjustable	400
Electromagnet mounted in central position	M
Thickness of brake disc 10 ... 16 mm or 18 ... 26 mm	12 25

## Example for ordering

Brake Caliper EV 028 FEM, supply voltage 400 VAC, electromagnet mounted in central position, thickness of brake disc 15 mm:

EV 028 FEM - 400 M - 12

## Advantages

The brake caliper EV 028 FEM or EH 028 FEM is a very compact and high efficient disc brake with very low power consumption. Its floating bearing compensates small misalignments of the brake disc. The attached electronic reduces automatically the power consumption in open position to 20 W.

## Options

- Inductive proximity switch: "Brake released", "Brake closed"-status and/or "Friction block wear adjustment necessary"

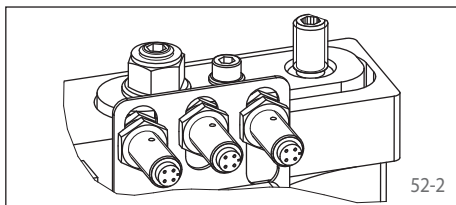

52-2

## Technical Data

	Brake Calipers EV 028 FEM and EH 028 FEM with supply voltage	
	230/240 VAC	380/400/415 VAC
Brake disc diameter	Braking torque	Braking torque
mm	Nm	Nm
300	660	940
355	810	1160
430	1020	1460
520	1270	1820
630	1580	2260
710	1800	2580
Clamping force	7000 N	10000 N
Clamping force or braking torque adjustable	80 - 100%	60 - 100%
Power consumption in open position	20 W (100% duty factor)	
Fuse rating	10A, "B"	
Switching frequency	240/h permanent activations at 20° C ambient temperature	
Switching time*	at least 10 seconds	
Weight	24 kg	

The braking torques shown in the table are based on a theoretical friction coefficient of 0,4.

\* shorter switching time on request

EDMAYR ANTRIEBSTECHNIK GmbH

Thalham 20

A-4880 St. Georgen im Attergau

Tel.: +43 7667 6840

Fax: +43 7667 20070

[www.edmayr.at](http://www.edmayr.at)  
[office@edmayr.at](mailto:office@edmayr.at)



# Brake Calipers EV 028 FEM and EH 028 FEM

spring activated – electromagnetically released

## Brake Caliper EV 028 FEM

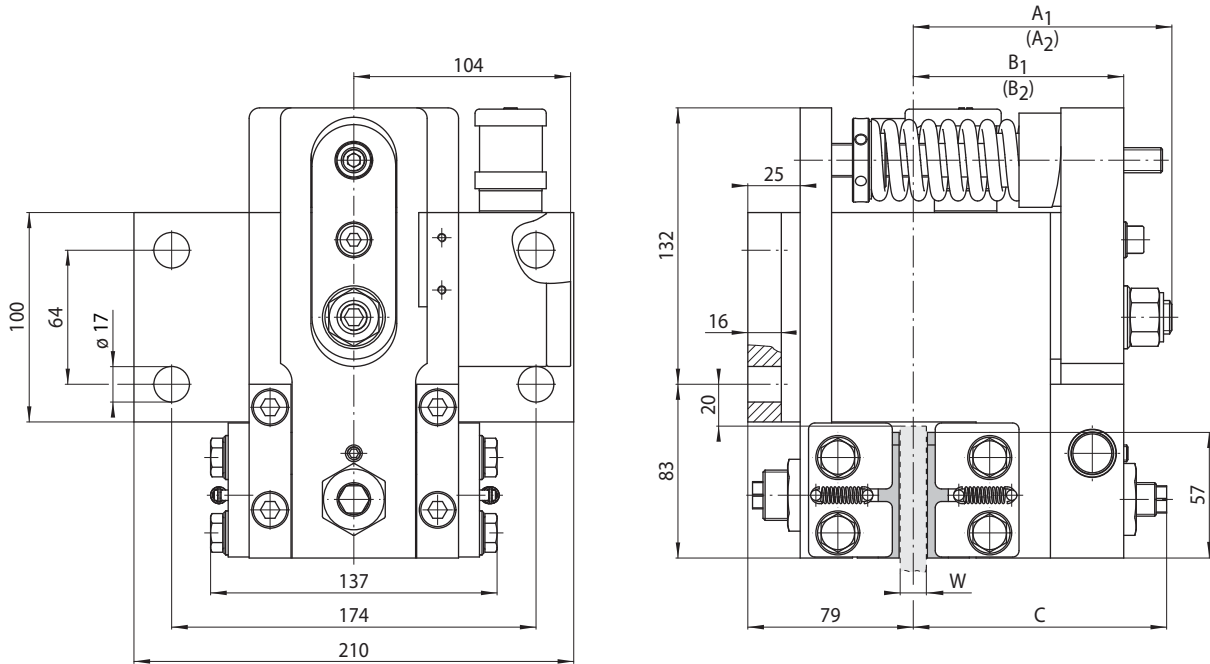

Thickness of brake disc W mm	A <sub>1</sub> mm	(A <sub>2</sub> ) mm	B <sub>1</sub> mm	(B <sub>2</sub> ) mm	C mm
10 ... 16	124	(139)	101	(118)	121
18 ... 26	129	(144)	106	(123)	127

Values in brackets resulting with friction block wear.

53-1

## Brake Caliper EH 028 FEM

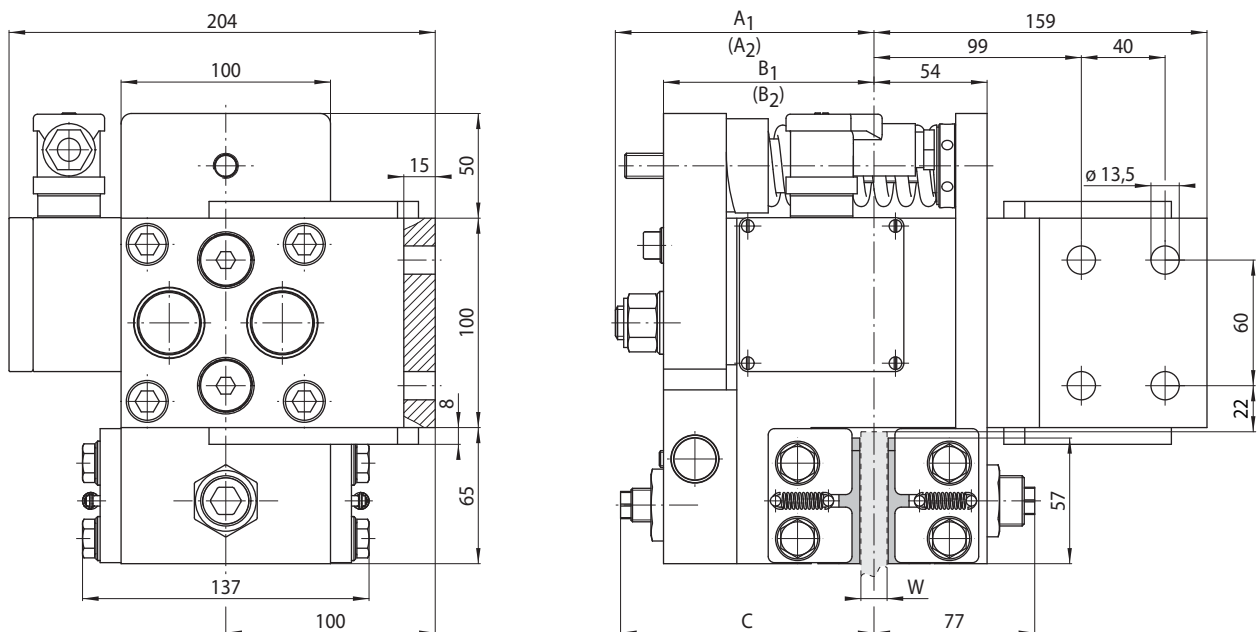

Thickness of brake disc W mm	A <sub>1</sub> mm	(A <sub>2</sub> ) mm	B <sub>1</sub> mm	(B <sub>2</sub> ) mm	C mm
10 ... 16	124	(139)	101	(118)	121
18 ... 26	129	(144)	106	(123)	127

Values in brackets resulting with friction block wear.

Edmayr Antriebstechnik GmbH

Thalham 20, 4880 St. Georgen im Attergau

Tel.: +43 7667 6840 Fax: +43 7667 20070

[office@edmayr.at](mailto:office@edmayr.at)

[www.edmayr.at](http://www.edmayr.at)

53-2