

Installation and Operating Instructions for Brake Caliper DV / DH 020 MKM

E 09.641e

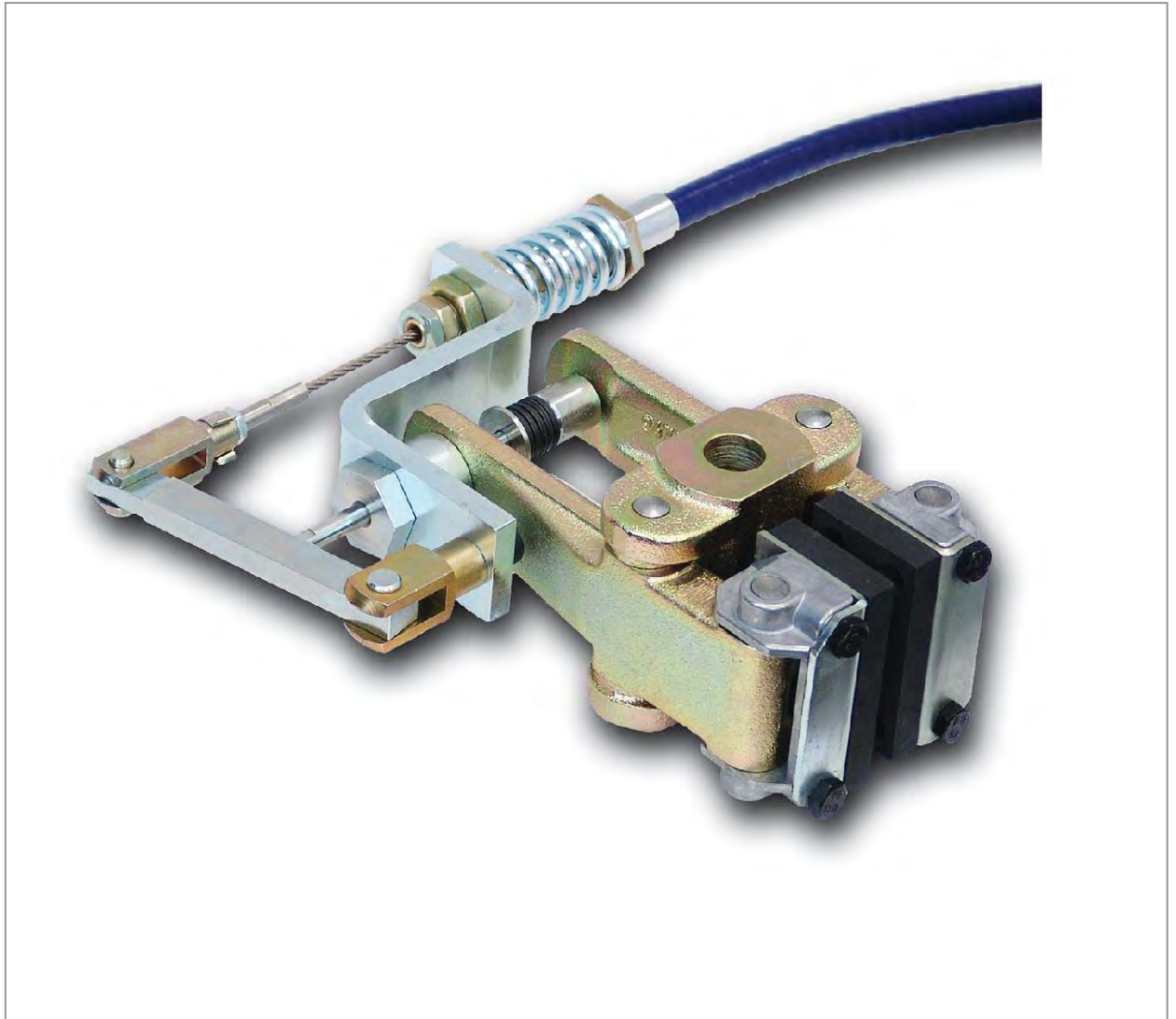

Contact:

Edmayr Antriebstechnik GmbH
Thalham 20, 4880 St. Georgen/Attg.
T: +43 7667 6840 F: +43 7667 20070
office@edmayr.at www.edmayr.at



EDMAYR
ANTRIEBSTECHNIK

EDMAYR ANTRIEBSTECHNIK	Installation and Operating Instructions for Brake Caliper DV 020 MKM and DH 020 MKM manually activated – manually released by Pull Cable			E 09.641e	
Stand: 30.08.2013	Version : 5	gez.: Su	gepr.: Ei	Seitenzahl: 11	Seite: 2

IMPORTANT

Please read these instructions carefully before installing and operating the product. Your particular attention is drawn to the notes on safety.

These installation and operating instructions are valid on condition that the product meets the selection criteria for its proper use. Selection and design of the product is not the subject of these installation and operating instructions.

Disregarding or misinterpreting these installation and operating instructions invalidates any product liability or warranty; the same applies if the product is taken apart or changed.

These installation and operating instructions should be kept in a safe place and should accompany the product if it is passed on to others – either on its own or as part of a machine – to make it accessible to the user.

SAFETY NOTICE

- Installation and operation of this product should only be carried out by skilled personnel.
- Repairs may only be carried out by the manufacturer or accredited agents.
- If a malfunction is indicated, the product or the machine into which it is installed, should be stopped immediately and either we or an accredited agent should be informed.
- Switch off the power supply before commencing work on electrical components.
- Rotating machine elements must be protected by the purchaser to prevent accidental contact.
- Supplies abroad are subject to the safety laws prevailing in those countries.

EDMAYR ANTRIEBSTECHNIK	Installation and Operating Instructions for Brake Caliper DV 020 MKM and DH 020 MKM manually activated – manually released by Pull Cable			E 09.641e	
	Stand: 30.08.2013	Version : 5	gez.: Su	gepr.: Ei	Seitenzahl: 11 Seite: 3

Contents

- 1. General information**
- 2. Configuration and function**
- 3. Drawing and parts list**
- 4. Condition at delivery**
- 5. Installation of the Brake Caliper**
 - 5.1 Installation
 - 5.2 Connecting the pull cable to the handbrake lever
 - 5.3 Pull cable-connection at the brake caliper
 - 5.4 Braking torque adjustment
 - 5.5 Running-in procedure
- 6. Maintenance**
 - 6.1 General maintenance
 - 6.2 Checking and adjusting braking torque
 - 6.3 Brake pads – checking brake pad wear and replacing pads

EDMAYR ANTRIEBSTECHNIK	Installation and Operating Instructions for Brake Caliper DV 020 MKM and DH 020 MKM manually activated – manually released by Pull Cable			E 09.641e	
	Stand: 30.08.2013	Version : 5	gez.: Su	gepr.: Ei	Seitenzahl: 11 Seite: 4

1. General information

This installation and operation instructions applies to:

- the DV 020 MKM, brake caliper mounted parallel to the brake disc (frame construction V, see Fig. 3.1, Section 3), pull cable mounted on the left.
- the DV 020 MKM, pull cable mounted on the right.
- the DH 020 MKM, brake caliper mounted at the right angle to the brake disc (frame construction H, see Fig. 3.2, Section 3).
- for installation on a brake disc with the thickness of 12.5 mm.
- various types of brake-pads, e.g. with wear alarm cable, increased glide speed, double friction surface or other special brake pad materials.

An ID plate with a 16-place part number is mounted on the brake caliper. The precise design of the brake caliper is defined by this part number only.

Please consult the drawings in each section when using this instructions.

2. Configuration and function

The brake caliper is used as a stopping and parking brake.

The brake calliper is opened and braking force is applied by actuation the handbrake lever. The handbrake lever (see Fig. 5.1, Section 5.2) can be secured simply by moving it above the zero point. No locking or unlocking mechanisms are required.

A spring actuator prevents sudden loss of holding / braking torque in the event of brake pad wear.

If for operational reasons occurs brake pad wear, can with the detented adjustment knob on the hand brake lever, a brake torque adjustment to be made, see Section 6.2.

Rotating parts must be secured by the user against inadvertent contact (e.g. brake disc).



Danger to life and limb!

It is essential to secure the entire drive train against inadvertent starts during brake installation and maintenance. Rotating components can cause severe injuries.

Therefore, rotating components (e.g. brake disc) must be secured by the operator to prevent accidental contact.

3. Drawing and parts list

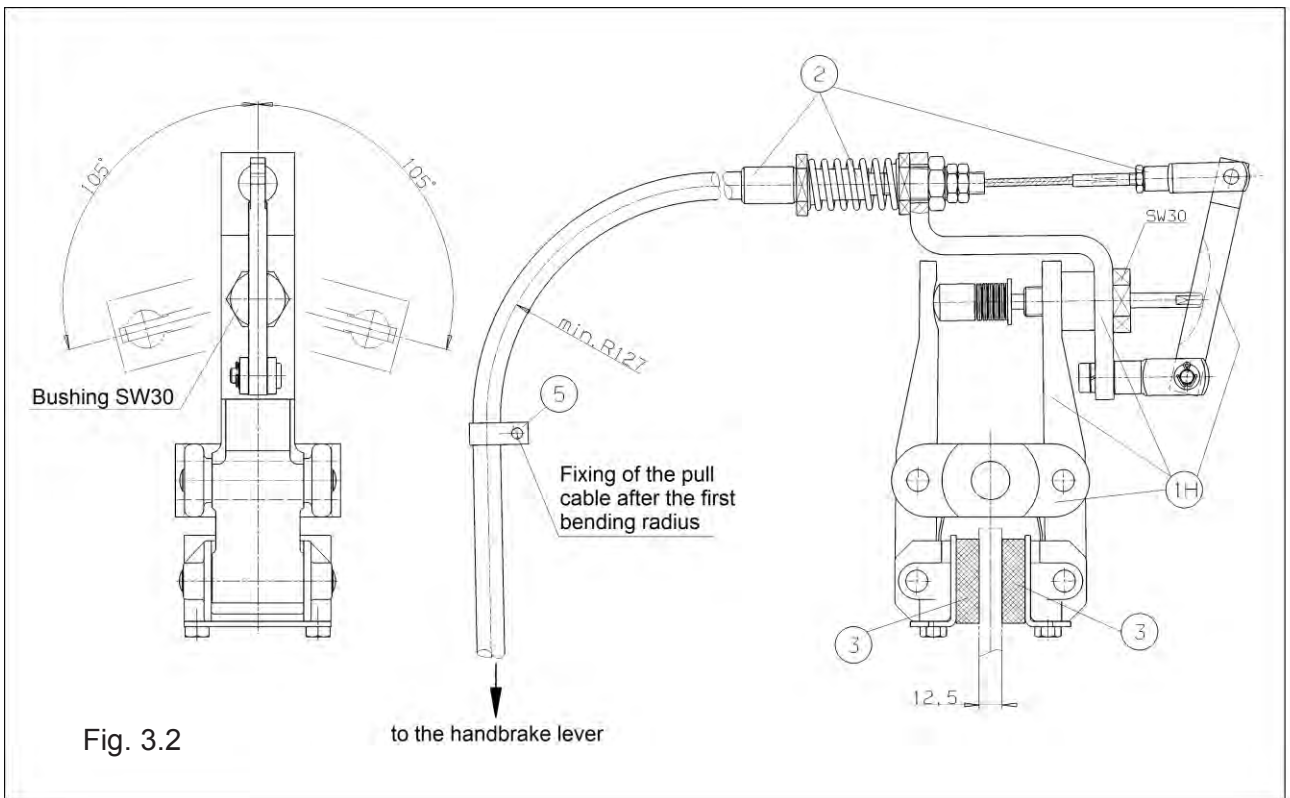
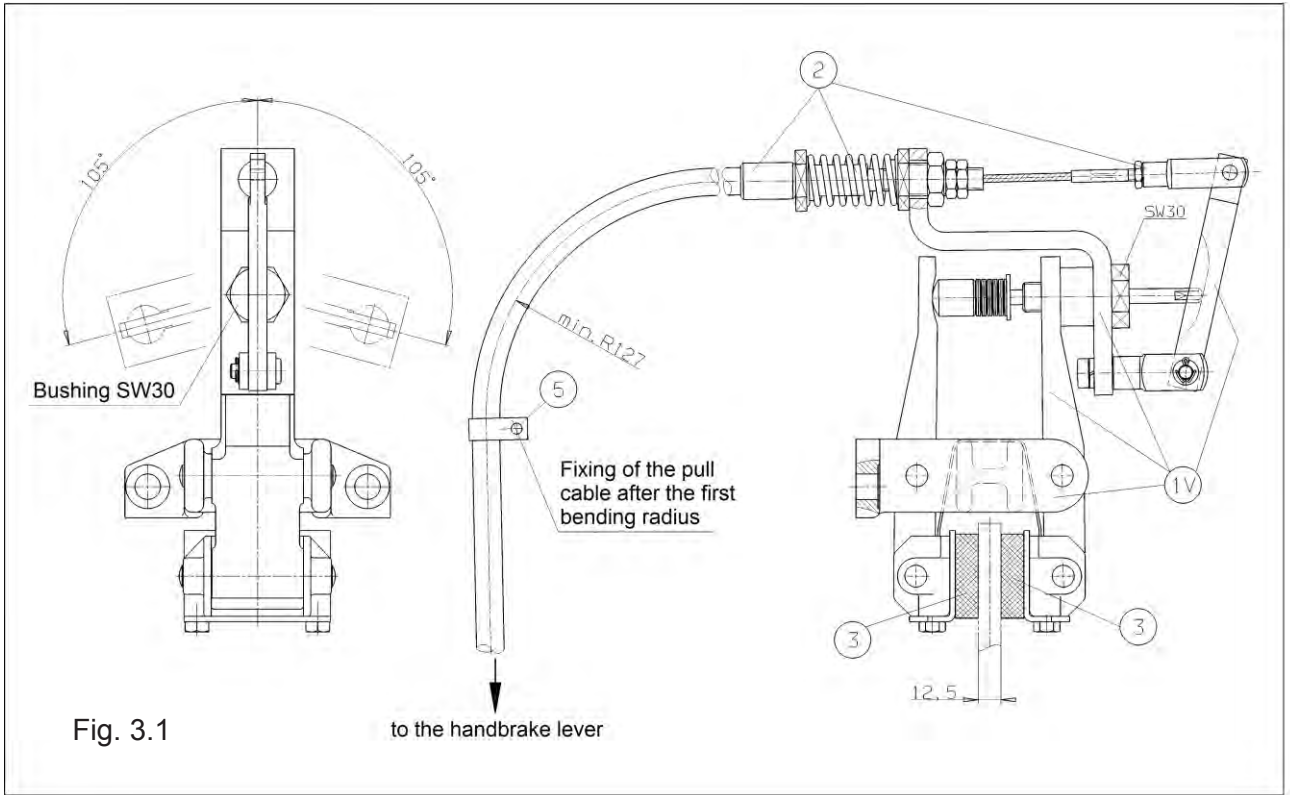

Parts list:

Part	Nomenclature	Quantity	Part number
1	Brake caliper DV 020 MKM	1	4457-103201-000000
	Brake caliper DH 020 MKM	1	4457-200201-000000
2	Pull cable for DV und DH 020 MKM	1	4584-809097-Ryyyyy**
3	Standard brake pad	2	2472-005013-A00112*
	Brake pad from BK 8006	2	2472-005013-A00109*
(Fig. 5.1)	Handbrake lever B 50452	1	4561-000001-R50452
5	Fastening clamps for cable size L and M		1563-001006-R00000

* Part number for 1 brake pad

**yyyyy = cable length in cm

4. Condition at delivery

The brake unit – consisting of the brake caliper, pull cable and handbrake lever – is delivered fully assembled. The adjusting knob on the handbrake lever is turned clockwise on the stop point to achieve the maximum gap between the brake pads. This allows for easy mounting of the brake pads to the 12.5 mm brake disc.

5. Installation of the Brake Caliper

Before installing the brake, the brake disc must be cleaned with alcohol, e.g. ethyl or isopropyl alcohol, or water-based surfactant solution (soapy water, etc.) and then rubbed dry with a clean cloth.

When cleaning the brake disc with a thinner, acetone or a brake cleaning agent, it is important to ensure that neither these cleaners nor any cleaner residues come in contact with the brake pads. This is especially important in the case of brakes used only as parking brakes, as no dynamic braking operations take place during which thinner residues would be rubbed off the brake disc.



Caution!

Oil and rust proofing agent residues reduce friction coefficients and thus diminish transmissible braking torque substantially!

EDMAYR ANTRIEBSTECHNIK	Installation and Operating Instructions for Brake Caliper DV 020 MKM and DH 020 MKM manually activated – manually released by Pull Cable			E 09.641e	
	Stand: 30.08.2013	Version : 5	gez.: Su	gepr.: Ei	Seitenzahl: 11 Seite: 7

5.1 Installation

The brake caliper should be mounted to stable, vibration-free machine components in order to ensure noise-free, screechless braking. During installation, it is essential to ensure that brake pads are centred and in full contact with the brake disc (the midlines of the brake arm must point to the midpoint of the brake disc). Maximum permissible lateral brake disc wobble is 0.2 mm. Greater wobble may cause rattling and shaking of the brake unit.

The brake caliper is mounted to the machine component with 2 M12 screws (mounting DV) or 1 M20 screw (mounting DH) the strength class 8.8.

If the pull cable must be positioned at a different angle, it may be repositioned as needed by up to $\pm 105^\circ$ relative to the midline of the handbrake lever after loosening the bushing (Fig. 3.1 and Fig. 3.2, bushing SW30).

In order to ensure uniform lift-off (ventilation) of the friction pads from the brake disc, you may make an attachment of the pull cable until after the first bending radius, see Fig. 3.1 and Fig. 3.2. The bending radius in the pull cable routing must be at least 127 mm.

The handbrake lever is with two M8 screws of strength class 8.8 attached to the machine parts. Make sure that you have between the two lever plates each arranged loosely included mounting sleeve, see Section A - A in Fig.5.1.

If the pull cable through openings and holes are must conducted, for which the handbrake lever is too large, the cable can be removed from the handbrake lever, see Section 5.2.



Caution!

Check to ensure that the brake disc rotates freely.



Caution!

When assembling, make sure that the brake pads are centred aligned and in full contact with the brake disc .

5.2 Connecting the pull cable to the handbrake lever

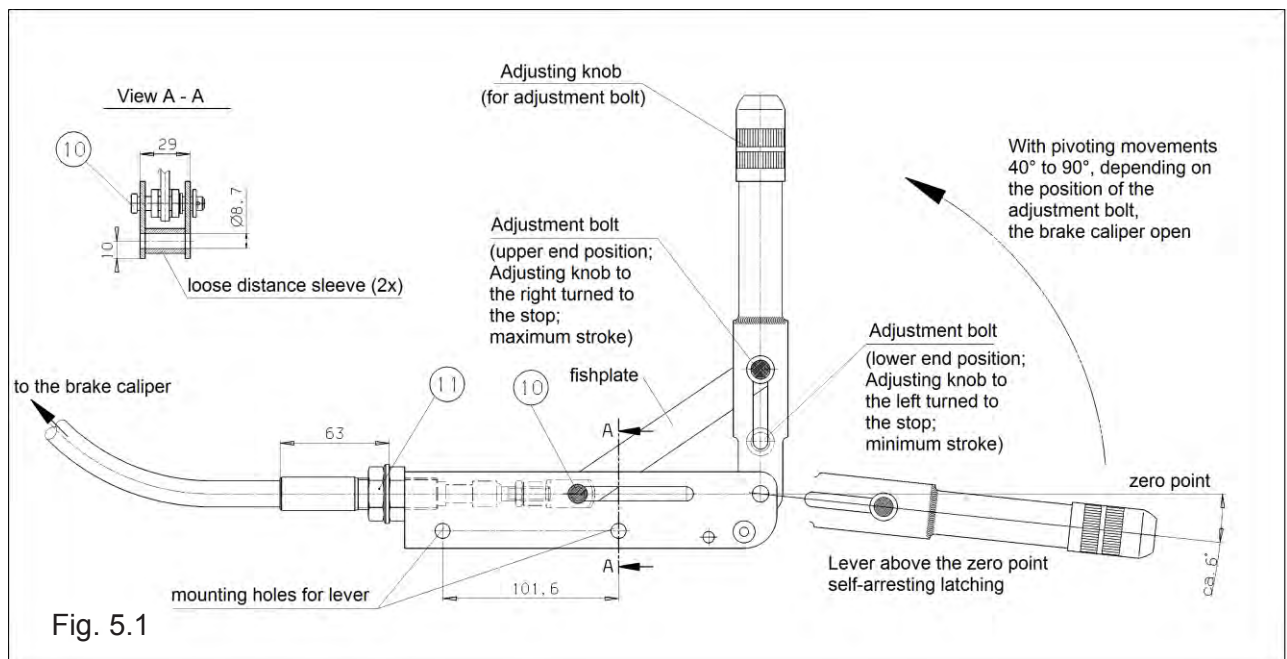

The pull cable is connected to the handbrake lever by the manufacturer. The pull cable can be detached if necessary using the following procedure:

- Remove the pin (Pos.10, Fig. 5.1), after setting aside the safety splint pin and put the washer to the side.
- Swing the fishplate out of the fork head.
- Loosen the lock nut M18x1,5 (Pos.11, Fig. 5.1)
- Remove the brake lever from the hose sleeve by turning to the left. The fishplate may not be in the fork head, otherwise the cable strand wire are not is twisted.
- You install the pull cables in reverse order, pay attention to this case the distance 63 mm. Do not forget to secure the pin (Pos.10, Fig. 5.1) by means of splint pin!

5.3 Pull cable-connection at the brake caliper

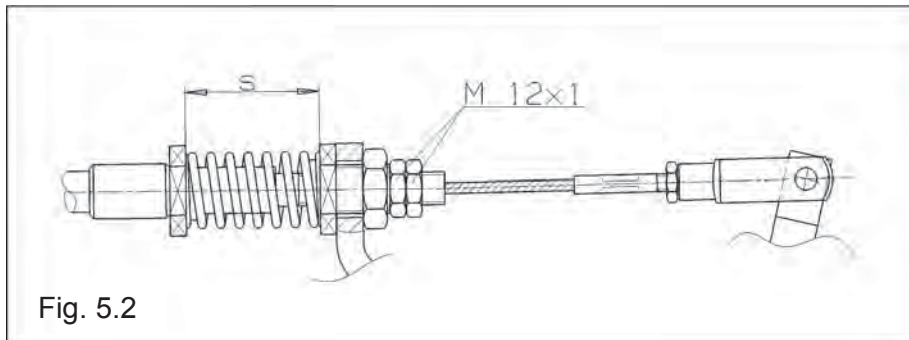

Fig. 5.2

The compensation spring is pre-tensed to dimension $s = 50$ mm by the 2 nuts (M12x1). (At this setting, the handbrake lever must not to be in self-arresting position over the zero point.)

5.4 Braking torque adjustment

Turn the adjusting knob on the handbrake lever to the stop point, which is the lower end position of the adjustment bolt (minimum pull cable stroke). Then swing the handbrake lever over the zero point, where it remains fixed in place. Measure the compression of the compensation spring in this position. It should equate to dimension "s" (see Fig. 5.2). Swing the lever back to the open brake position. Turn the adjusting knob clockwise by 1 revolution, swing the lever over the zero point again and check dimension "s". Repeat this procedure until you have set dimension "s" to 41 mm at the zero point. This equates to a tensile force of 700 N for maximum holding and braking torque.

**Caution!**

Further compression of the compensation spring is not permitted, as it may result in destruction of the brake caliper!

5.5 Running-in procedure

Optimum braking effect is achieved only when both brake pads (3) are in full contact with the brake disc and the brake pads have attained a temperature of approx. 200°C. A few times, short brake when the brake disc rotates, is therefore necessary.

**Caution!**

If running-in cannot be performed, the braking torques specified in our catalog no. 46 cannot be achieved. Reductions of up to 50% are possible.

EDMAYR ANTRIEBSTECHNIK	Installation and Operating Instructions for Brake Caliper DV 020 MKM and DH 020 MKM manually activated – manually released by Pull Cable			E 09.641e	
	Stand: 30.08.2013	Version : 5	gez.: Su	gepr.: Ei	Seitenzahl: 11 Seite: 10

6. Maintenance

Maintenance should be performed on the brake calliper at intervals of 4 to 12 weeks, depending upon the frequency and duration of operation.

6.1 General maintenance

- Check both brake caliper arms for ease of movement.
- Clean all bearing and glide points
- Lubricate all bearing and glide points.



Caution!

Brake pads must not come in contact with lubricants.



Danger to life and limb!

When disassembling the brake is to ensure that the entire drive train is protected against accidental activation. Rotating components can cause severe injuries. Therefore, rotating components (e.g. brake disc) must be secured by the operator to prevent accidental contact by the operator.

Check for tight bolt/screw connections:

- brake caliper to machine component
- bracket for the cable attachment (SW30) on the brake caliper lever arm
- brake pads to brake caliper lever arms
- handbrake lever to machine component

6.2 Checking and adjusting braking force

Prüfen Sie bei geschlossener Bremszange, Handbremshebel befindet sich über den 0-Punkt
Perform the check when the brake caliper is closed. The handbrake lever is positioned over the zero point (and remains fixed in this self-arresting position). Dimension "s" as shown in Fig.5.2. If the gap has increased beyond 41 mm, braking torque must be readjusted by gradually turning the adjusting knob clockwise as described in Section 5.4.

6.3 Brake pads – checking brake pad wear and replacing pads

The degree of brake pad wear is determined on the basis of two criteria. If one of these criteria is fulfilled, the brake pads must be replaced.

- If the adjustment bolt on the handbrake lever to be in the upper end position and the adjustment bolt is turned clockwise on to the stop point, no further readjustment for wear is possible. Further brake pad wear will result in a loss of holding/braking torque.

EDMAYR ANTRIEBSTECHNIK	Installation and Operating Instructions for Brake Caliper DV 020 MKM and DH 020 MKM manually activated – manually released by Pull Cable			E 09.641e	
	Stand: 30.08.2013	Version : 5	gez.: Su	gepr.: Ei	Seitenzahl: 11 Seite: 11

- The brake pad material must not be worn to within less than 4 mm (residual brake pad thickness) to the steel base plates!

Brake pads or brake linings (Pos.3) must always be replaced in pairs. Fixed spanner or ring spanner SW 13 are required to remove and replace the brake pads. Turn the adjusting knob on the handbrake lever counter-clockwise on the stop point. Replace the worn brake pads. Readjust the brake caliper as described in Section 5.4.



Danger to life and limb!

The brake pads may be replaced only when the plant or the working machine is standstill!



Caution!

Brake pads must always be replaced in pairs.

Contact:

Edmayr Antriebstechnik GmbH
 Thalham 20, 4880 St. Georgen/Attg.
 T: +43 7667 6840 F: +43 7667 20070
office@edmayr.at www.edmayr.at



EDMAYR
ANTRIEBSTECHNIK