

Installation and Operating Instruction for Brake Caliper DV / DH 020 FHM

E 09.621e

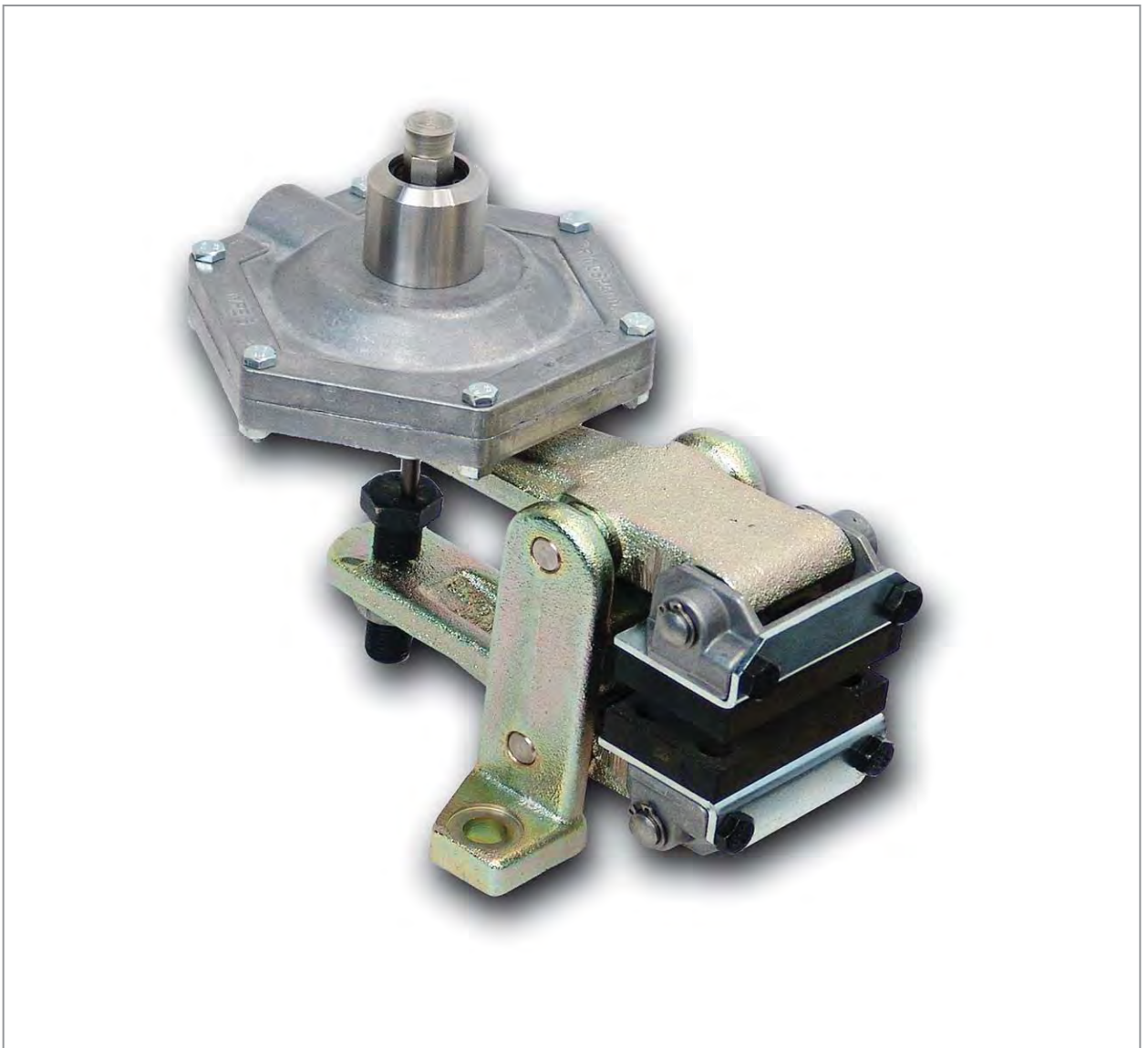

Kontakt:

Edmayr Antriebstechnik GmbH

Thalham 20, 4880 St. Georgen/Attg.

T: +43 7667 6840 F: +43 7667 20070

office@edmayr.at

www.edmayr.at



EDMAYR
ANTRIEBSTECHNIK

EDMAYR ANTRIEBSTECHNIK	Installation and Operating Instruction for Brake Caliper DV / DH 020 FHM spring-activated, hydraulically released			E 09.621e	
Issue: 28.02.2014	Version : 6	drawn: Su	checked: Su	Pages: 10	Page: 2

Important

Please read these instructions carefully before installing and operating the product. Your particular attention is drawn to the notes on safety.

These installation and operating instructions are valid on condition that the product meets the selection criteria for its proper use. Selection and design of the product is not the subject of these installation and operating instructions.

Disregarding or misinterpreting these installation and operating instructions invalidates any product liability or warranty; the same applies if the product is taken apart or changed.

These installation and operating instructions should be kept in a safe place and should accompany the product if it is passed on to others – either on its own or as part of a machine – to make it accessible to the user.

Safety Notice

- Installation and operation of this product should only be carried out by skilled personnel.
- Repairs may only be carried out by the manufacturer or accredited agents.
- If a malfunction is indicated, the product or the machine into which it is installed, should be stopped immediately and either we or an accredited agent should be informed.
- Switch off the power supply before commencing work on electrical components.
- Rotating machine elements must be protected by the purchaser to prevent accidental contact.
- Supplies abroad are subject to the safety laws prevailing in those countries.

EDMAYR ANTRIEBSTECHNIK	Installation and Operating Instruction for Brake Caliper DV / DH 020 FHM spring-activated, hydraulically released			E 09.621e	
	Issue: 28.02.2014	Version : 6	drawn: Su	checked: Su	Pages: 10 Page: 3

Contents

- 1. General information**
- 2. Configuration and function**
- 3. Drawing and parts list**
- 4. Condition at delivery**
- 5. Installation of the brake caliper**
 - 5.1 Installation
 - 5.2 Pressure oil line connection
 - 5.3 Brake caliper adjustment
 - 5.4 Breaking-in procedure
 - 5.5 Electrical connection for inductive proximity switch
- 6. Maintenance**
 - 6.1 General maintenance
 - 6.2 Checking and adjusting braking force
 - 6.3 Permissible brake pad wear
- 7. Replacement of worn parts**
 - 7.1 Brake pads
 - 7.2 Brake chamber

EDMAYR ANTRIEBSTECHNIK	Installation and Operating Instruction for Brake Caliper DV / DH 020 FHM spring-activated, hydraulically released			E 09.621e	
	Issue: 28.02.2014	Version : 6	drawn: Su	checked: Su	Pages: 10 Page: 4

1. General information

This installation and operation guide applies to:

- the standard version of the DV 020 FHM, brake caliper mounted parallel to the brake disc (frame construction V, see Fig 3.1, Section 3). Brake chamber mounted on the right.
- the version with the brake chamber mounted on the left. (on the attachment page)
- the version with inductive proximity switch
- the version of the DH 020 FHM, brake caliper mounted at the right angle to the brake disc (frame construction H, see Fig. 3.2, Section 3).
- for installation on a brake disc with the thickness of 12.5 mm.
- the various brake pad types, e.g. with cable for wear monitoring, higher glide speed, double contact area and different pad materials.

An ID plate with a 16-place part number is mounted on the brake caliper. The precise design of the brake caliper is defined by this part number only.

Please consult the drawings in each section when using this guide.



Danger to life and limb!

It is essential to secure the entire drive train against inadvertent starts during brake installation and maintenance. Rotating components can cause severe injuries. Therefore, rotating components (e.g. brake disc) must be secured by the operator to prevent accidental contact.

2. Configuration and function

The brake caliper is used as a stopping brake and a parking brake.

Braking force is generated by a spring, pos. 16 (see Fig. 3.1, Section 3). It is released (opened) hydraulically (hydraulic fluid). If brake pads (pos. 3, Fig. 3.1) are worn, braking and holding force is diminished, as the tension in the spring (pos. 16) is reduced.

If brake pads are worn, brake pad wear must be checked and braking force adjusted as described in Section 6.2.

Rotating parts must be secured by the user against inadvertent contact (e.g. brake disc).

3. Drawing and parts list

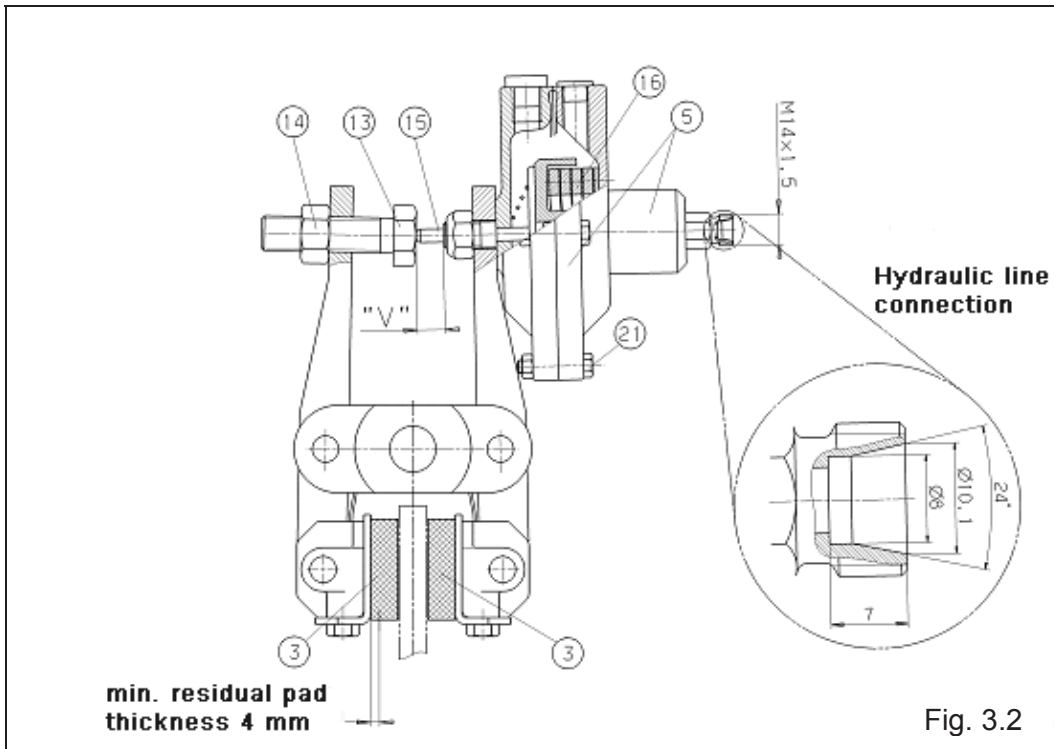
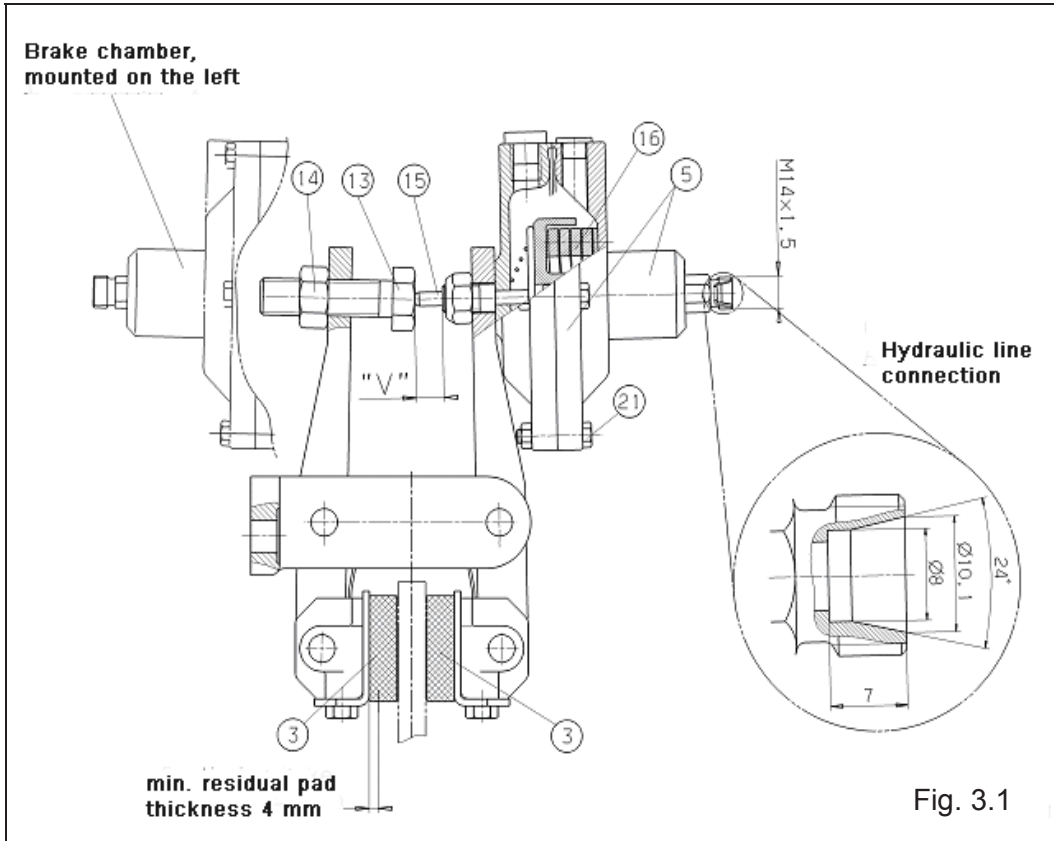

Parts list:

Part	Nomenclature	Quantity	Part number
5	Brake chamber	1	3514-032118-000000
3	Standard brake pad for brake caliper: 4457-103915-000000 4457-200800-000000 4457-201801-000000	2	2472-005013-A00112*

* Part number for 1 brake pad.

4. Condition at delivery

The brake caliper is not ready for operation as delivered. The brake caliper is delivered with a clamping gap of 13.5 mm between brake pads. This allows for installation or mounting without hydraulic pressure.



Caution!

In order to ensure proper brake calliper function, all steps described in Sections 5.1 to 5.4 must be performed after installation!

5. Installation of the brake caliper

Before installing the brake, the brake disc must be cleaned with alcohol, e.g. ethyl or isopropyl alcohol, or water-based surfactant solution (soapy water, etc.) and then rubbed dry with a clean cloth.

When cleaning the brake disc with a thinner, acetone or a brake cleaning agent, it is important to ensure that neither these cleaners nor any cleaner residues come in contact with the brake pads. This is especially important in the case of brakes used only as parking brakes, as no dynamic Braking operations take place during which thinner residues would be rubbed off the brake disc.



Caution!

Oil and rust proofing agent residues reduce friction coefficients and thus diminish transmissible braking torque substantially!

5.1 Installation

The brake caliper should be mounted to stabile, vibration-free machine components in order to ensure noise-free, screechless braking. During installation, it is essential to ensure that brake pads are centred and in full contact with the brake disc (the midlines of the brake arm must point to the midpoint of the brake disc).

Maximum permissible lateral brake disc wobble is 0.2 mm. Greater wobble may cause rattling and shaking of the brake unit.

EDMAYR ANTRIEBSTECHNIK	Installation and Operating Instruction for Brake Caliper DV / DH 020 FHM spring-activated, hydraulically released			E 09.621e	
	Issue: 28.02.2014	Version : 6	drawn: Su	checked: Su	Pages: 10 Page: 7

As a rule, the bolt (13) shown in Fig. 3.1 is turned into the brake arm to the point at which the caliper can be mounted to the brake disc (thickness 12.5 mm) without hydraulic pressure. If this is not possible, loosen the counter nut (pos. 14) and turn the bolt (pos. 13) further into the brake arm.



Caution!

Following mounting or installation, braking force must be adjusted as described in Section 5.3.

The brake caliper is using: 2 screws M12 (type DV 20) or
 1 screw M20 (type DH 20)
 the strenght class 8.8 attached on the machine part.

5.2 Pressure oil line connection

Minimum required hydraulic pressure is 65 bar; maximum permissible pressure is 100 bar.

A flexible hose must be used, i.e. a DN 6 high-pressure hose with a dynamic operating pressure capacity of up to 145 bar. The hydraulic connection on the brake chamber has bore type W in accordance with DIN 3861 (24° countersink) with M14x1.5 outside thread.

Maximum hydraulic fluid consumption per braking operation is approx. 2.5cm³ .

Recommended hydraulic fluids: Hydraulic fluids (mineral oils) of types H-L, H-LP or H-LPD may H-LPD be used.

5.3 Brake caliper adjustment



Caution!

The braking/holding force must be adjusted prior to initial operation.

- Pressurize the brake chamber with 65 to 70 bar oil pressure.

Note:

Pressure during subsequent operation must be equal to or greater than this adjustment pressure, as the brake caliper will otherwise fail to open completely during normal operation, resulting in possible brake pad rubbing.

- Loosen the counter nut (14) and turn the bolt (13) on the pushrod (15) shown in Fig.3.1 clockwise until the gap between the brake pads and the brake disc is reduced to approx. 0.2 – 0.4 mm but the brake pads do not rub against the brake disc.

Note:

The minimum adjustable gap depends on the actual degree of lateral brake disc wobble. Smaller gaps increase the wear reserve, i.e. the interval between brake caliper adjustments.

- Secure the bolt (13) by tightening the counter nut (14).



Caution!

It is important to ensure that the brake pads (3) do not rub against the brake disc when the brake is released.

When pressure is released from the brake chamber, the full braking (holding) force is applied.

5.4 Breaking-in procedure

Optimum braking effect is achieved only when both brake pads (3) are in full contact with the brake disc and the brake pads have attained a temperature of approx. 200°C. This requires multiple, brief braking while the brake disc is rotating (breaking-in).



Caution!

If breaking-in is not performed, the braking forces cited in our publication no. 46 cannot be achieved. Reductions of up to 50% are possible.

Note:

If it is not possible to break in the unit while the brake caliper is fully engaged (exposed to full spring pressure), braking force can be reduced by decreasing air pressure (10...40 bar).

5.5 Electrical connection for inductive proximity switch

The caliper is equipped with a DC 12V02PSLK inductive proximity switch manufactured by DIEL:

Switch function	: PNP (closer)	Switch gap	: 2 mm flush-mountable
Operating voltage	: 10...35 V DC	max. sw. current	: 0...200 mA
Voltage loss	: < or = 1,5 V	rev. charge protected	: yes
Temp. range	: -25 to +80°C	Safety class	: IP 67
Connection	: 2m PVC cable	Housing	: M12x1 V4A

Fig. 5.1: Circuit diagram, PNP technology

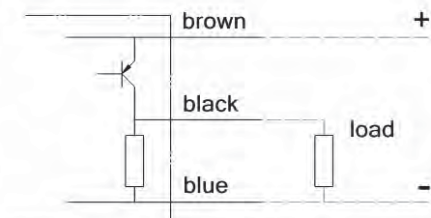

The proximity switch is positioned in such a way that it is activated by the spring plate when the spring-pressure cylinder is pressurized (oil pressure > 65 bar).

When pressure is removed, the brake contracts and the spring plate moves out of the field controlled by the switch (which is no longer activated).

EDMAYR ANTRIEBSTECHNIK	Installation and Operating Instruction for Brake Caliper DV / DH 020 FHM spring-activated, hydraulically released			E 09.621e	
	Issue: 28.02.2014	Version : 6	drawn: Su	checked: Su	Pages: 10 Page: 9

Procedure for mounting or replacing the proximity switch:

The following instructions apply to the proximity switch described above with a 2-mm switch gap.

To prevent twisting of the connector cable, install the proximity switch before making the electrical connections.

Pressurize the spring-pressure cylinder to 65 – 70 bar oil pressure. Pressurize the spring-pressure cylinder to 65 – 70 bar oil pressure. The brake caliper opens and the spring plate is moved to the end position. Screw the proximity switch into the threaded bore (M12x1) until it abuts with the spring plate. From this position, turn the proximity switch carefully clockwise, approximately one revolution. Secure this position with the counter nut. Connect the proximity switch. The sensor LED must now light up. Test for proper function by activating the brake caliper several times. When the brake caliper is activated under hydraulic pressure (pressure oil), the LED must respond (light up) regularly and reliably.

6. Maintenance

Maintenance should be performed on the brake calliper at intervals of 4 to 12 weeks, depending upon the frequency and duration of operation.

6.1 General maintenance

- Check both brake caliper arms for ease of movement.
- Clean all bearing and glide points
- Lubricate all bearing and glide points.

Note:

It is important to ensure that the pushrod (pos. 15) is properly lubricated with grease at the exit point.



Caution!

Brake pads must not come in contact with lubricants.

Check for tight bolt/screw connections:

- brake caliper to machine part
- brake chamber to brake caliper arm
- brake pads to brake caliper arms
- brake chamber flange connection

Check the following for proper seal/leaks:

- hose connections

6.2 Checking and adjusting braking force

- Check braking force and spring tension.
- When the brake caliper is closed, measure how far the pushrod (pos. 15) on the brake chamber shown in Fig. 3.1 (see Section 3) protrudes toward the threaded pin, dimension "V".

EDMAYR ANTRIEBSTECHNIK	Installation and Operating Instruction for Brake Caliper DV / DH 020 FHM spring-activated, hydraulically released			E 09.621e	
	Issue: 28.02.2014	Version : 6	drawn: Su	checked: Su	Pages: 10 Page: 10



Caution!

When brake pads are worn, tension in the spring (pos. 16, Fig. 3.1, Section 3) is reduced and the distance the pushrod (pos.15, dimension“V”) shown in Fig. 3.1 protrudes increases. This reduces braking force.
At a protrusion distance of 17 mm, at the latest, braking force must be readjusted as described in Section 5.3.

6.3 Permissible break pad wear

Brake pad material must have a thickness of at least 4 mm (from the top surface of the brake pad to the top surface of the steel mounting plate). Brake pads or brake linings (pos. 3) must always be replaced in pairs.

7. Replacement of worn parts

7.1 Brake pads

Before replacing brake pads, ensure that the mass held by the brake is secured against movement or twisting, as the brake must be released in order to replace the brake pads. Filling the brake chamber with pressure oil until the brake to opens. Loosen the counter nut (14) and turn the bolt (13) into the brake caliper until the brake pads can be replaced easily.

Fixed spanner or ring spanner SW 13 are required to remove and replace the brake pads.

After replacing the brake pads, readjust braking force as described in Section Punkt 5.3.

7.2 Brake chamber

The brake chamber is defective when the pushrod (pos. 15) does not move when pressure is applied or released or when air escapes from the cylinder. To the extent possible, inspection and repair should be performed by the manufacturer only.



Caution! Danger of injury

Brake chamber 3514-032118-000000 is equipped with a highly pre-tensed spring (16). Spring pressure is not completely relieved when the cylinder flange bolts (21) are loosened or removed.

Contact:

Edmayr Antriebstechnik GmbH
Thalham 20, 4880 St. Georgen/Attg.
T: +43 7667 6840 F: +43 7667 20070
office@edmayr.at www.edmayr.at



EDMAYR
ANTRIEBSTECHNIK