

Brake Caliper DV 020 FKM

spring activated – manually released
by Pull Cable

Edmayr Antriebstechnik GmbH
Thalham 20, 4880 St. Georgen im Attergau
Tel.: +43 7667 6840 Fax: +43 7667 20070
office@edmayr.at www.edmayr.at

EDMAYR

ANTRIEBSTECHNIK

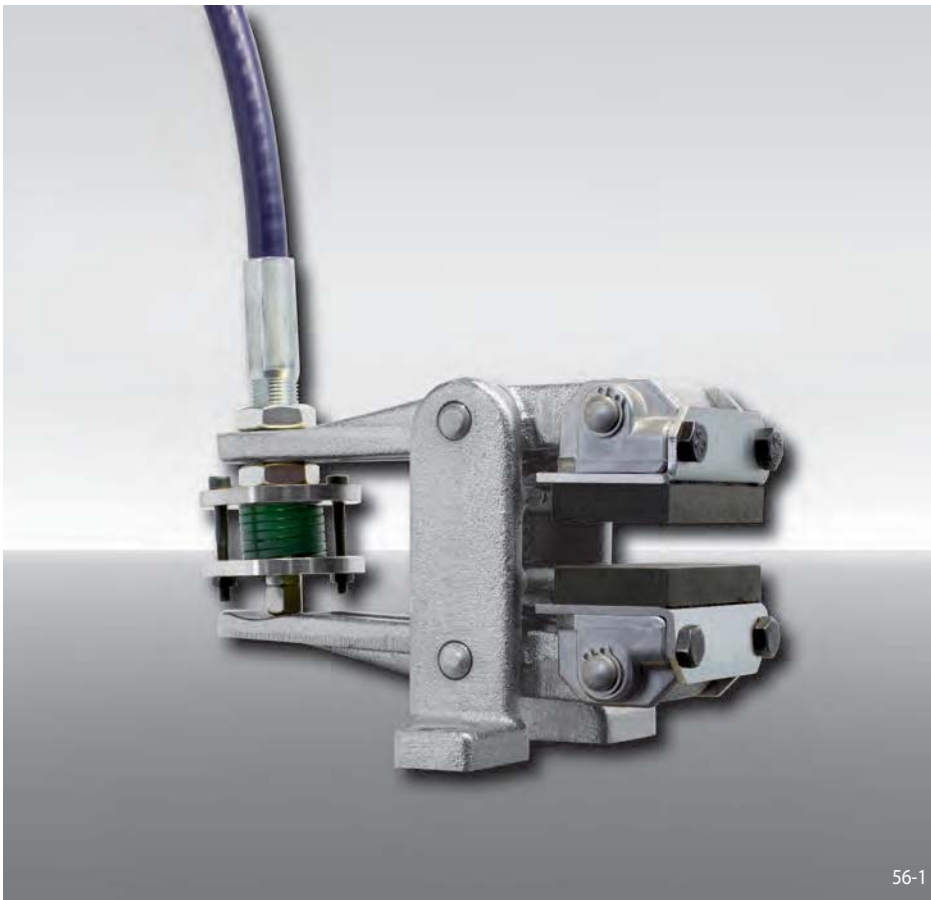

56-1

Features

Features	Code
Brake Caliper	D
Mounting to the machine parallel to the brake disc	V
Frame size 020	020
Spring activated	F
Manually released	K
Manual adjustment to accommodate friction block wear	M
Pressure spring 510	510
Pull Cable installation mounted right or left available	R L
Thickness of brake disc 12,5 mm	12

Example for ordering

Brake Caliper DV 020 FKM, pressure spring 510, Pull Cable installation mounted right, thickness of brake disc 12,5 mm:

DV 020 FKM - 510 R - 12

Technical Data

Brake Caliper DV 020 FKM with pressure spring 510	
Brake disc diameter	Braking torque
mm	Nm
200	160
250	210
300	270
355	330
430	410
520	510
Clamping force	2750 N
Weight	4,4 kg

The braking torques shown in the table are based on a theoretical friction coefficient of 0,4.

Accessories

The Brake Caliper can be delivered fully assembled with RCS® Pull Cable and Hand Brake Lever. Please indicate the required cable length.

For further information regarding RCS® Pull Cable and Hand Brake Lever see page 121.

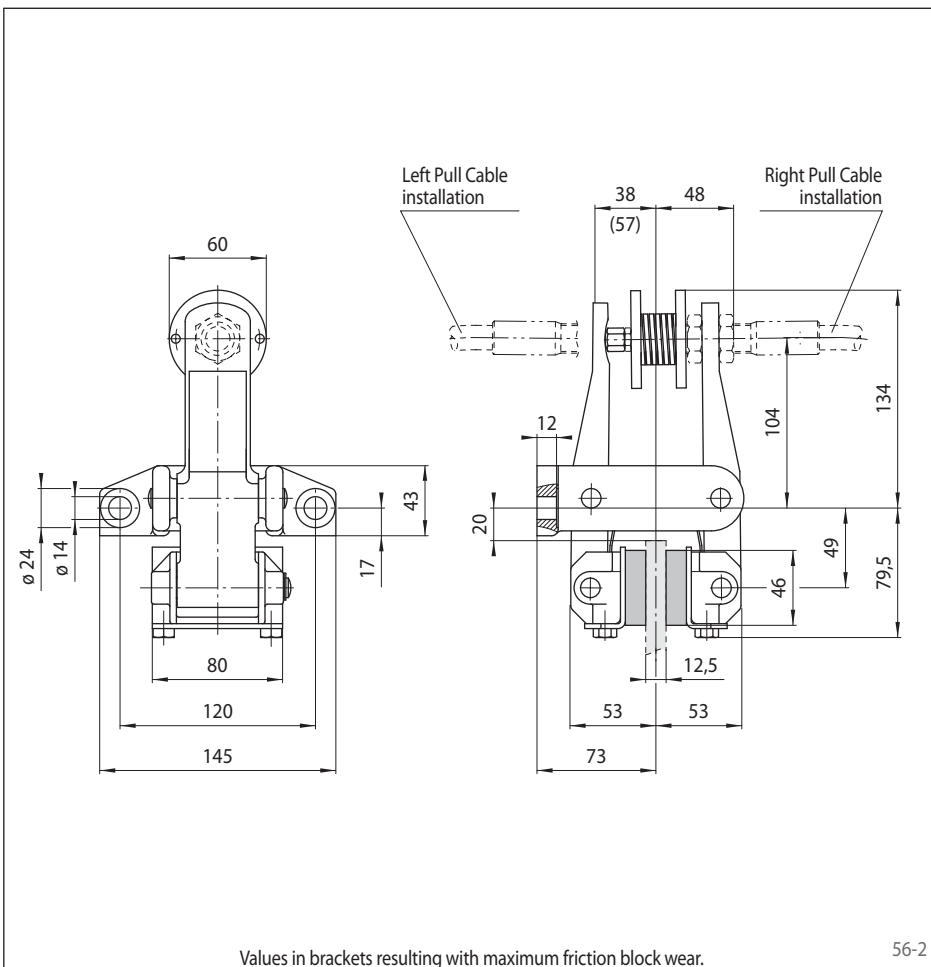

Values in brackets resulting with maximum friction block wear.

56-2