

Brake Caliper DH 030 FHA

spring activated – hydraulically released



Features

Features	Code
Brake Caliper	D
Mounting to the machine at right angles to the brake disc	H
Frame size 030	030
Spring activated	F
Hydraulically released	H
Automatic adjustment to accommodate friction block wear	A
Thruster 240	240
Thruster mounted right or left available	R L
Thickness of brake disc 12,5 mm or 25 mm	12 25

Example for ordering

Brake Caliper DH 030 FHA, thruster 240, thruster mounted right, thickness of brake disc 12,5 mm:

DH 030 FHA - 240 R - 12

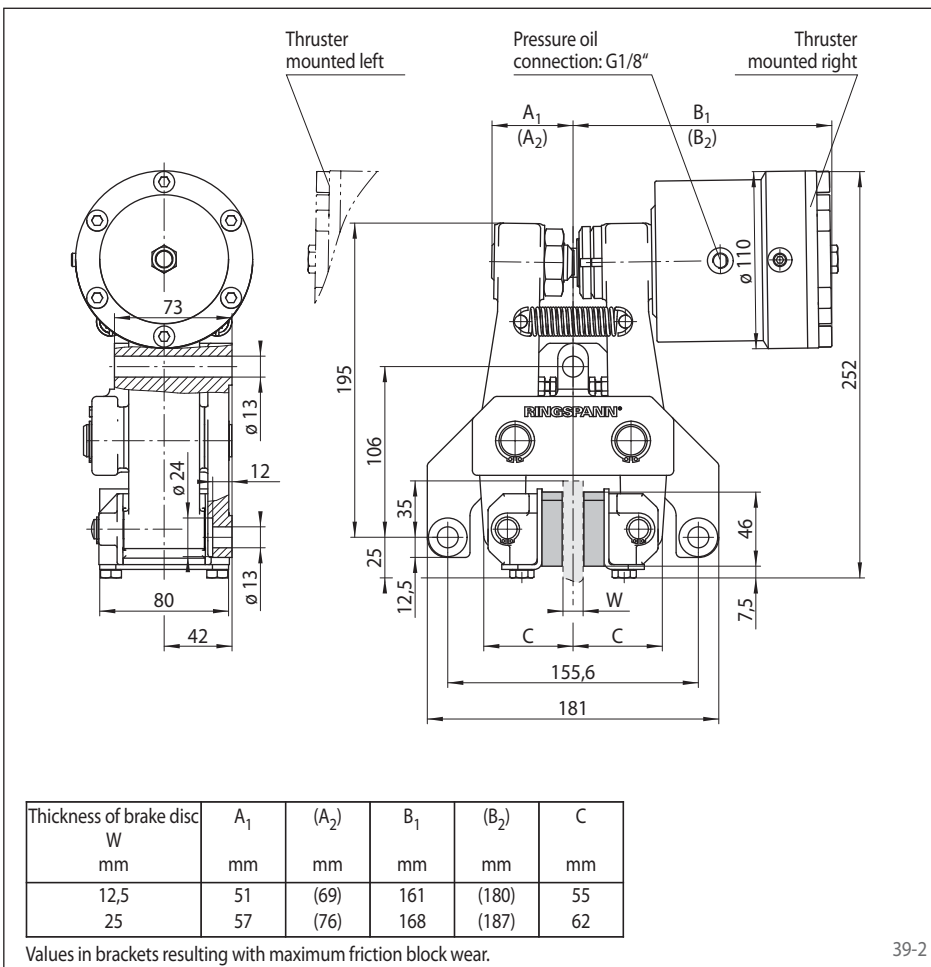

Technical Data

Brake Caliper DH 030 FHA with thruster 240	
Brake disc diameter mm	Braking torque Nm
200	620
250	840
300	1100
355	1300
430	1600
520	2000
Clamping force	11000 N
Oil pressure	min. 40 bar max. 120 bar
Oil volume	max. 6 cm ³
Weight	13,8 kg

The braking torques shown in the table are based on a theoretical friction coefficient of 0,4.

Edmayr Antriebstechnik GmbH
 Thalham 20, 4880 St. Georgen im Attergau
 Tel.: +43 7667 6840 Fax: +43 7667 20070
office@edmayr.at www.edmayr.at