

Brake Caliper DH 012 FEM

spring activated – electromagnetically released



Features

Features	Code
Brake Caliper	D
Mounting to the machine at right angles to the brake disc	H
Frame size 012	012
Spring activated	F
Electromagnetically released	E
Manual adjustment to accommodate friction block wear	M
Electromagnet for 110 V	410
Electromagnet for 230 V	420
Thruster mounted right or left available	R L
Thickness of brake disc 12,5 mm	12

Example for ordering

Brake Caliper DH 012 FEM, electromagnet for 110 V, thruster mounted right, thickness of brake disc 12,5 mm:

DH 012 FEM - 410 R - 12

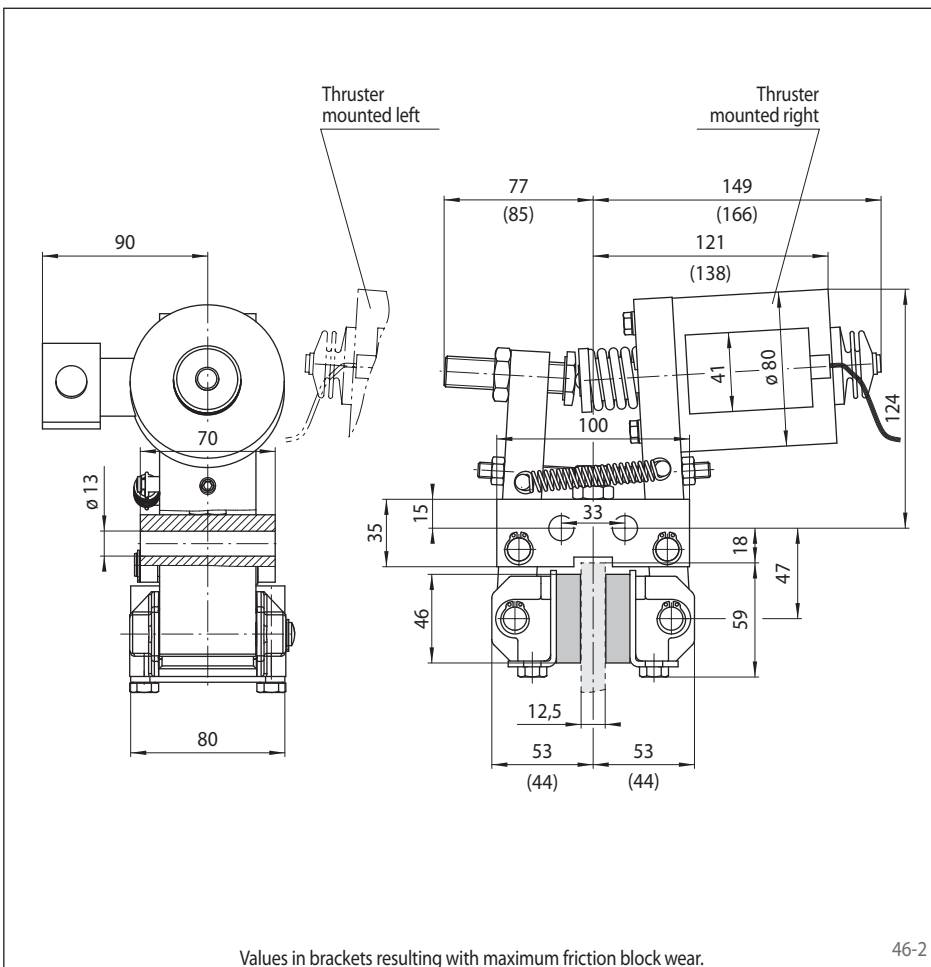

Technical Data

Brake disc diameter	Brake Caliper DH 012 FEM	
	with electromagnet 410 for 110 V	with electromagnet 420 for 230 V
mm	Braking torque Nm	
200	94	
250	130	
300	160	
355	200	
430	250	
520	310	
Clamping force	1650 N	
Power consumption in open position	12 W (100% duty factor)	
Fuse rating	6 A	
Switching frequency	600/h permanent activations at 20° C ambient temperature	
Weight	7 kg	

The braking torques shown in the table are based on a theoretical friction coefficient of 0,4.

Accessories

Universal Transformer see page 120.

Edmayr Antriebstechnik GmbH

Thalham 20, 4880 St. Georgen im Attergau

Tel.: +43 7667 6840 Fax: +43 7667 20070

office@edmayr.at

www.edmayr.at